

N-channel 650 V, 0.35 Ω typ., 12 A MDmesh™ II Power MOSFETs in TO-220FP and I²PAKFP packages

Datasheet - production data

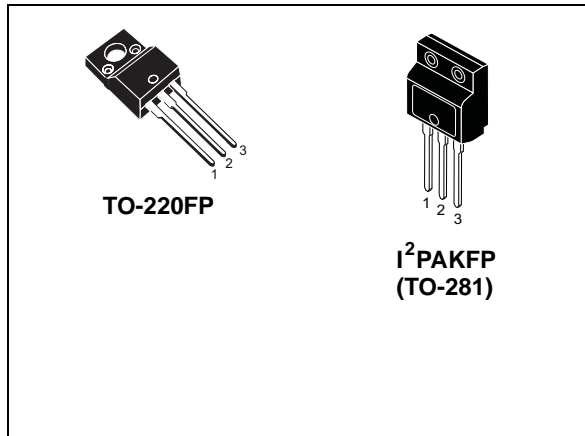
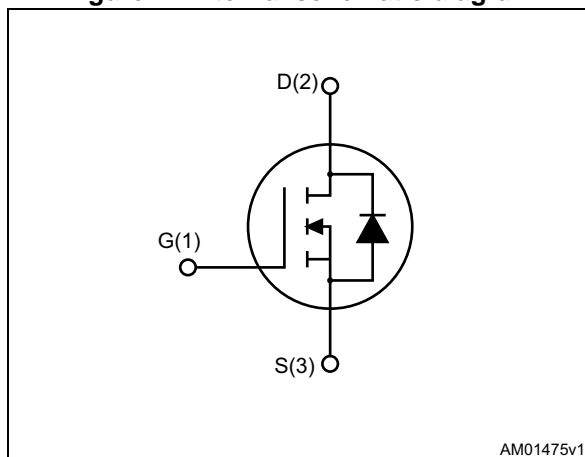

Figure 1. Internal schematic diagram



Features

Order code	V _{DSS} @T _{jmax}	R _{DS(on)} max.	I _D
STF15NM65N	710 V	0.38 Ω	12 A
STFI15NM65N			

- 100% avalanche tested
- Low input capacitance and gate charge
- Low gate input resistance

Applications

- Switching applications

Description

These devices are N-channel Power MOSFETs developed using the second generation of MDmesh™ technology. This revolutionary Power MOSFETs associates a vertical structure to the company's strip layout to yield one of the world's lowest on-resistance and gate charge. It is therefore suitable for the most demanding high efficiency converters.

Table 1. Device summary

Order code	Marking	Packages	Packing
STF15NM65N	15NM65N	TO-220FP	Tube
STFI15NM65N		I ² PAKFP (TO-281)	

Contents

- 1 Electrical ratings 3**
- 2 Electrical characteristics 4**
 - 2.1 Electrical characteristics (curves) 6
- 3 Test circuits 8**
- 4 Package information 9**
 - 4.1 TO-220FP package information 10
 - 4.2 I2PAKFP (TO-281) package information 12
- 5 Revision history 14**

1 Electrical ratings

Table 2. Absolute maximum ratings

Symbol	Parameter	Value		Unit
		TO-220FP	I ² PAKFP	
V _{DS}	Drain source voltage	650		V
V _{GS}	Gate source voltage	± 25		V
I _D	Drain current continuous T _C = 25 °C	12 ⁽¹⁾		A
I _D	Drain current continuous T _C = 100 °C	7.56		A
I _{DM} ⁽²⁾	Drain current pulsed	48		A
P _{TOT}	Total dissipation at T _C = 25 °C	30		W
dv/dt ⁽³⁾	Peak diode recovery voltage slope	15		V/ns
V _{ISO}	Insulation withstand voltage (RMS from all three leads to external heatsink (t = 1 s; T _C = 25 °C)	2500		V
T _J	Operating junction temperature range	-55 to 150		°C
T _{stg}	Storage temperature range			

1. Limited by maximum junction temperature.

2. Pulse width limited by safe operating area.

3. I_{SD} ≤ 12 A, di/dt ≤ 400 A/μs, V_DSpeak ≤ V_{(BR)DSS}, V_{DD} = 80 % V_{(BR)DSS}

Table 3. Thermal data

Symbol	Parameters	Value		Unit
		TO-220FP	I ² PAKFP	
R _{thjc}	Thermal resistance junction-case	4.17		°C/W
R _{thj-amb}	Thermal resistance junction-ambient	62.5		°C/W

Table 4. Avalanche characteristics

Symbol	Parameters	Value	Unit
I _{AS}	Avalanche current, repetitive or not-repetitive (pulse width limited by T _{jmax})	3	A
E _{AS}	Single pulse avalanche energy (starting T _J = 25 °C, I _D = I _{AR} , V _{DD} = 50 V)	187	mJ

2 Electrical characteristics

($T_{CASE} = 25\text{ °C}$ unless otherwise specified).

Table 5. On/off states

Symbol	Parameter	Test conditions	Min.	Typ.	Max.	Unit
$V_{(BR)DSS}$	Drain-source breakdown voltage	$V_{GS} = 0, I_D = 1\text{ mA}$	650			V
I_{DSS}	Zero gate voltage drain current	$V_{DD} = 650\text{ V}, V_{GS} = 0$			1	μA
		$V_{DD} = 650\text{ V}, V_{GS} = 0$ $T_C = 125\text{ °C}^{(1)}$			100	μA
I_{GSS}	Gate body leakage	$V_{GS} = \pm 25\text{ V}, V_{DS} = 0\text{ V}$			± 100	nA
$V_{GS(th)}$	Gate threshold voltage	$I_D = 250\text{ }\mu\text{A}, V_{GS} = V_{DS}$	2	3	4	V
$R_{DS(on)}$	Static drain-source on-resistance	$I_D = 6\text{ A}, V_{GS} = 10\text{ V}$		0.35	0.38	Ω

1. Defined by design, not subject to production test

Table 6. Dynamic

Symbol	Parameter	Test conditions	Min.	Typ.	Ma.	Unit
C_{iss}	Input capacitance	$V_{DS} = 50\text{ V}, f = 1\text{ MHz},$ $V_{GS} = 0\text{ V}$	-	983	-	pF
C_{oss}	Output capacitance		-	57	-	pF
C_{rss}	Reverse capacitance		-	4.5	-	pF
$C_{osseq}^{(1)}$	Equivalent output capacitance	$V_{DS} = 0\text{ V to } 520\text{ V}, V_{GS} = 0\text{ V}$	-	146	-	pF
R_g	Intrinsic gate resistance	$f = 1\text{ MHz } I_D = 0\text{ A}$	-	4.6	-	Ω
Q_g	Total gate charge	$V_{DD} = 520\text{ V}, I_D = 12\text{ A},$ $V_{GS} = 10\text{ V}$ (see Figure 13: Gate charge test circuit)	-	33.3	-	nC
Q_{gs}	Gate source charge		-	5.7	-	nC
Q_{gd}	Gate-drain charge		-	17	-	nC

1. Cross eq: defined as a constant equivalent capacitance giving the same charging time as C_{OSS} when V_{DS} increases from 0 to 80 % V_{DSS} .

Table 7. Switching times

Symbol	Parameter	Test conditions	Min.	Typ.	Max.	Unit
$t_{d(on)}$	Turn-on delay time	$V_{DD} = 325\text{ V}, I_D = 6\text{ A}$ $R_g = 4.7\text{ }\Omega, V_{GS} = 10\text{ V}$ (see Figure 12: Switching times test circuit for resistive load and Figure 17: Switching time waveform)	-	55.5	-	ns
t_r	Rise time		-	8.5	-	ns
$t_{d(off)}$	Turn-off-delay time		-	14	-	ns
t_f	Fall time		-	11.4	-	ns

Table 8. Source drain diode

Symbol	Parameter	Test conditions	Min.	Typ.	Max.	Unit
I_{SD}	Source drain current		-		12	A
$I_{SDM}^{(1)}$	Source drain current (pulsed)		-		48	A
$V_{SD}^{(2)}$	Forward on voltage	$I_{SD} = 12 \text{ A}$, $V_{GS} = 0 \text{ V}$	-		1.6	V
t_{rr}	Reverse recovery time	$I_{SD} = 12 \text{ A}$, $di/dt = 100 \text{ A}/\mu\text{s}$ $V_{DD} = 60 \text{ V}$ (see Figure 14: Test circuit for inductive load switching and diode recovery times)	-	428		ns
Q_{rr}	Reverse recovery charge		-	4.7		μC
I_{RRM}	Reverse recovery current		-	21.5		A
t_{rr}	Reverse recovery time	$I_{SD} = 12 \text{ A}$, $di/dt = 100 \text{ A}/\mu\text{s}$ $V_{DD} = 60 \text{ V}$, $T_j = 150 \text{ }^\circ\text{C}$ (see Figure 14: Test circuit for inductive load switching and diode recovery times)	-	570		ns
Q_{rr}	Reverse recovery charge		-	6.2		μC
I_{RRM}	Reverse recovery current		-	22		A

1. Pulse width limited by safe operating area.
2. Pulsed: pulse duration = 300 μs , duty cycle 1.5 %

2.1 Electrical characteristics (curves)

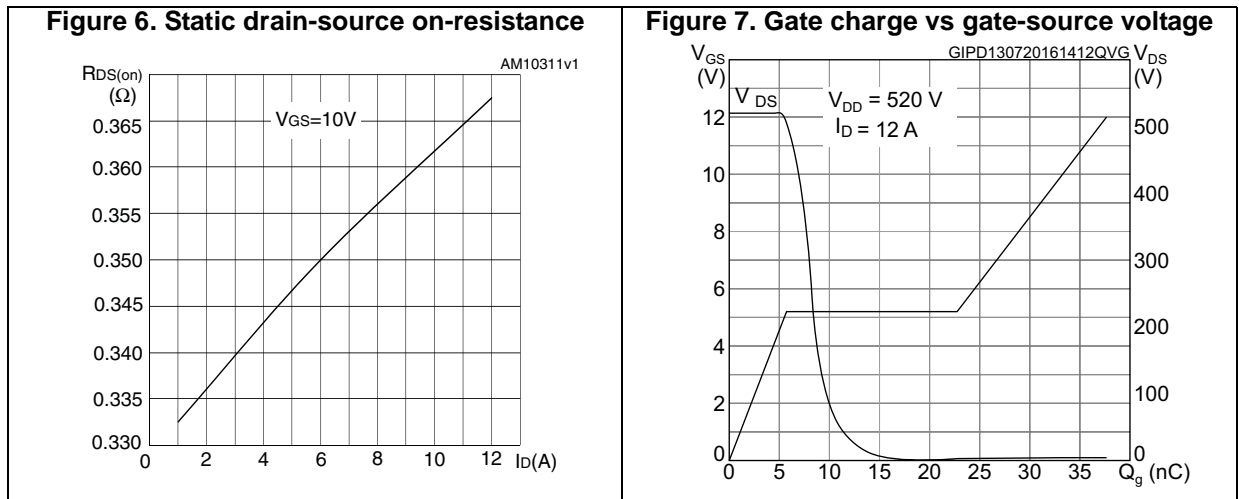
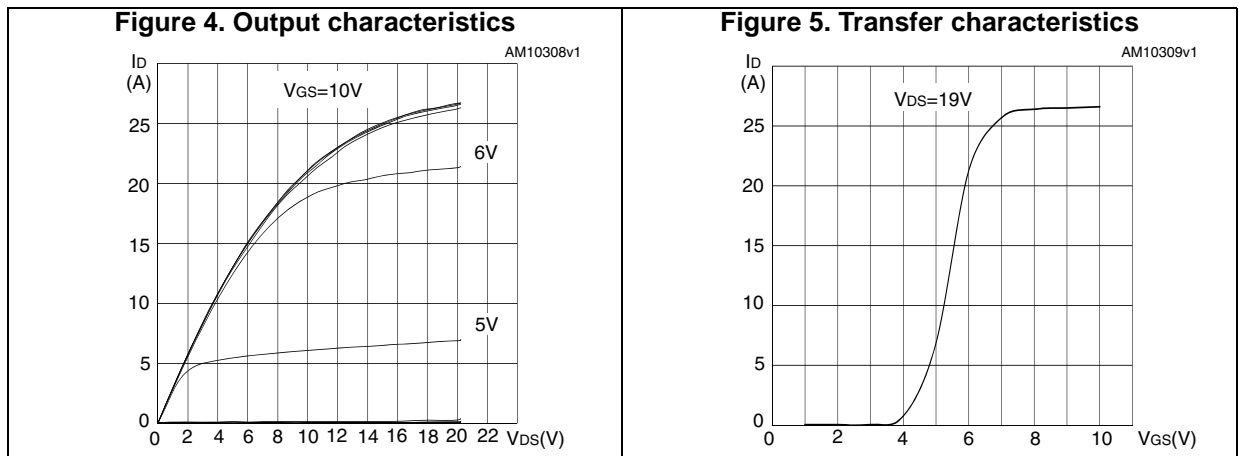
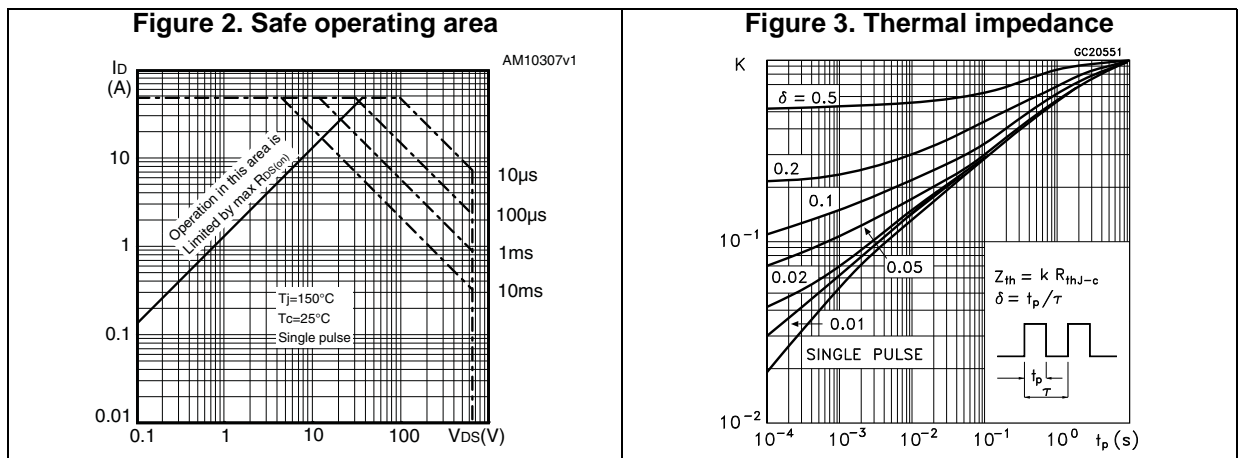

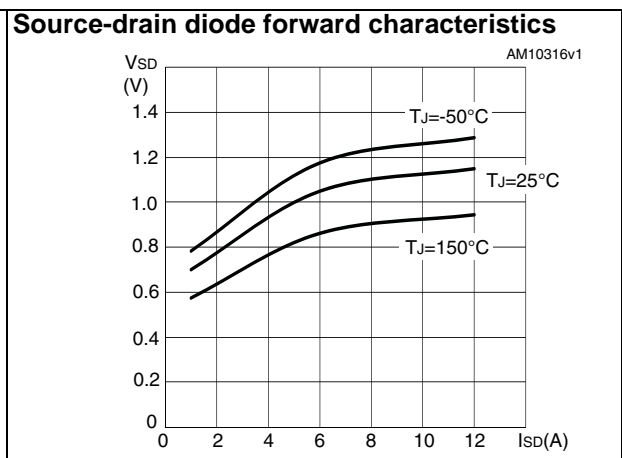
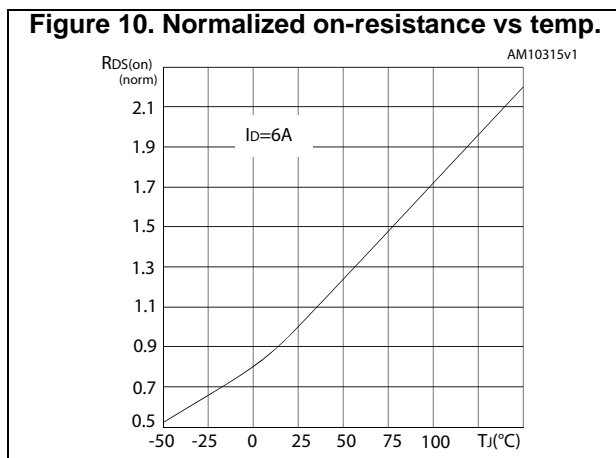
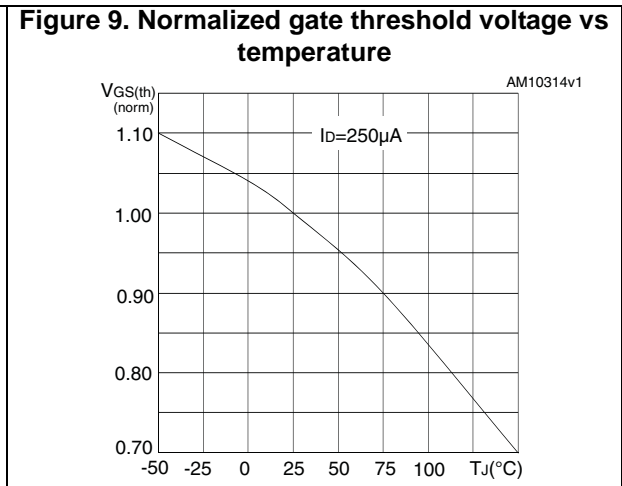
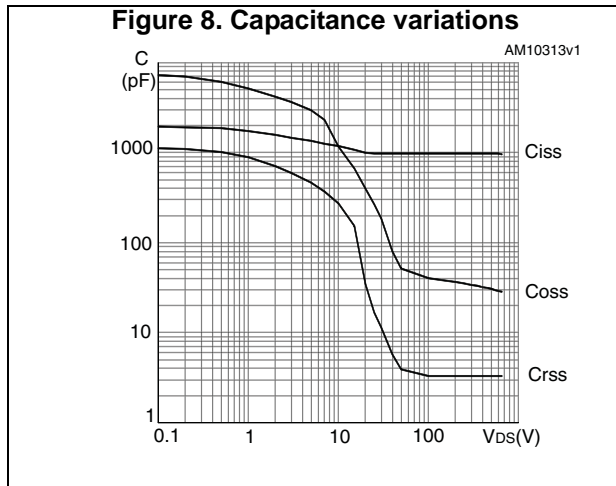
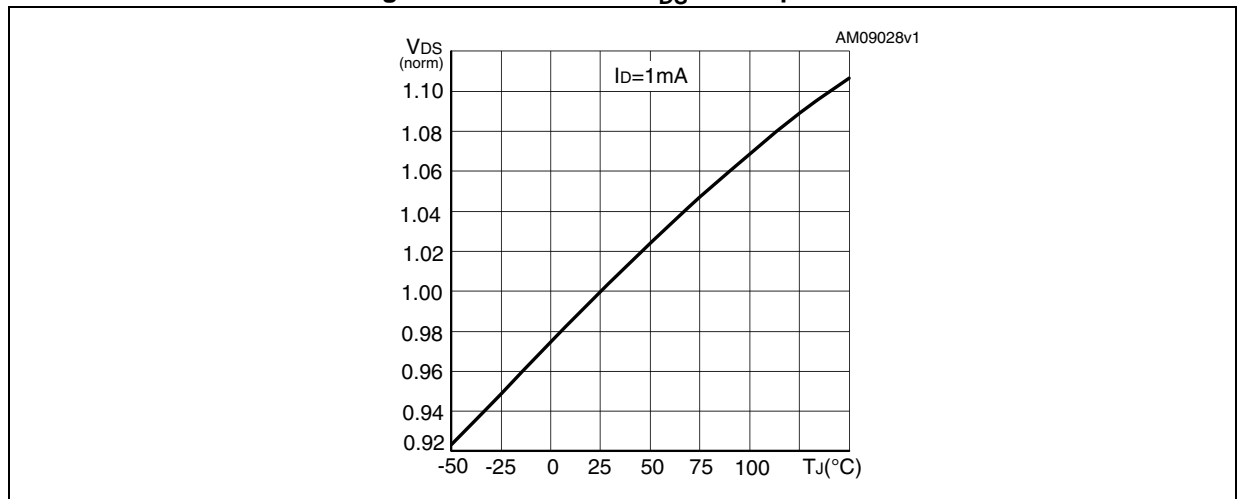

Figure 11. Normalized V_{DS} vs temperature



3 Test circuits

Figure 12. Switching times test circuit for resistive load

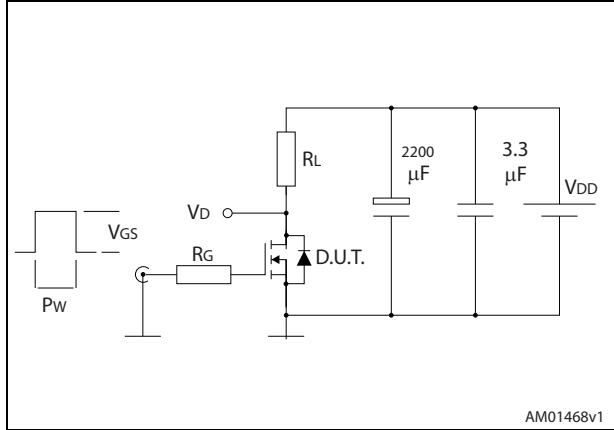

Figure 13. Gate charge test circuit

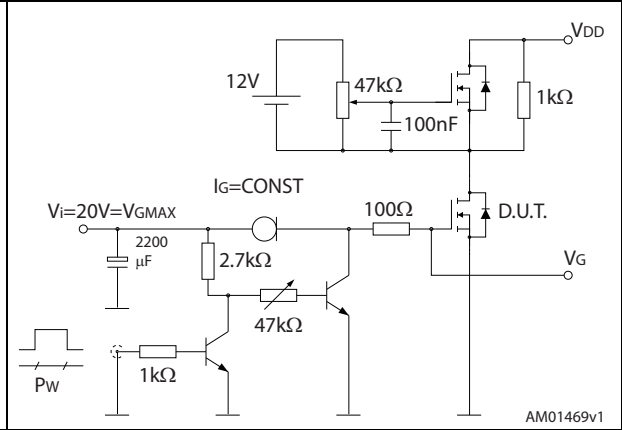

Figure 14. Test circuit for inductive load switching and diode recovery times

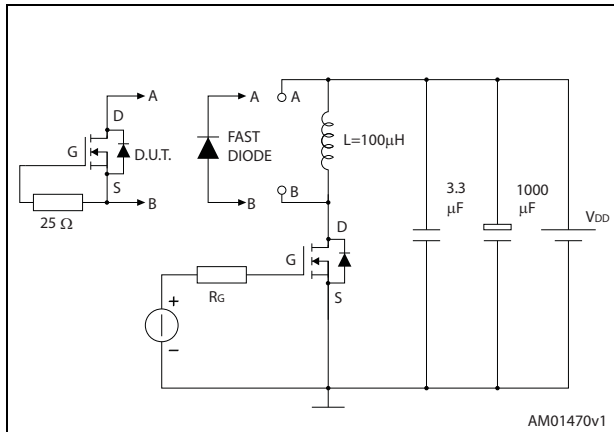

Figure 15. Unclamped inductive load test circuit

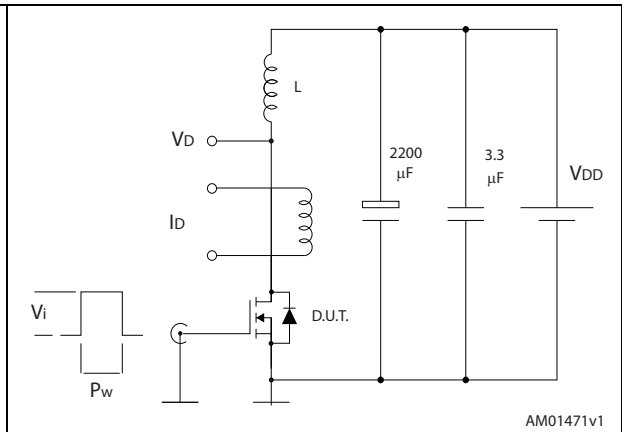

Figure 16. Unclamped inductive waveform

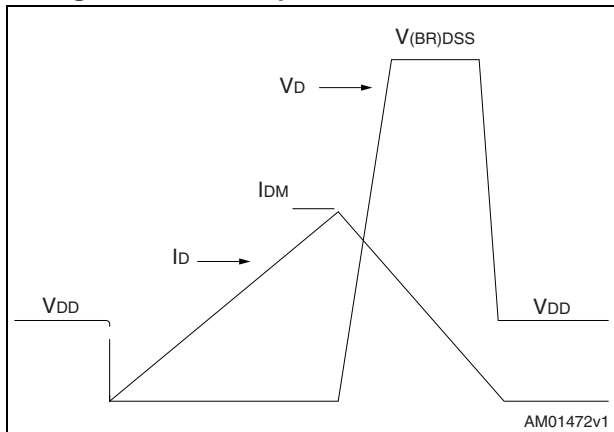
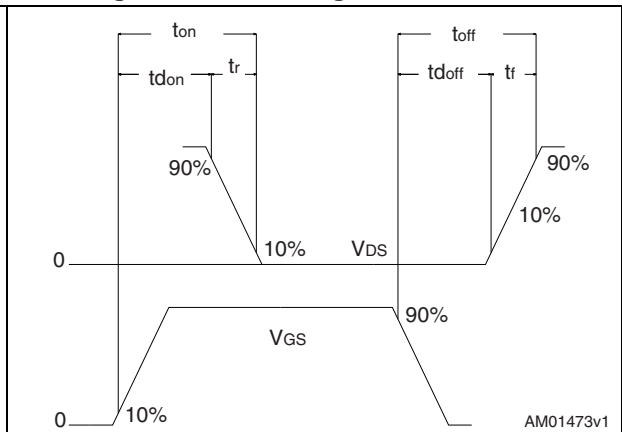

Figure 17. Switching time waveform



4 Package information

In order to meet environmental requirements, ST offers these devices in different grades of ECOPACK[®] packages, depending on their level of environmental compliance. ECOPACK[®] specifications, grade definitions and product status are available at: www.st.com. ECOPACK[®] is an ST trademark.

Table 9. TO-220FP package mechanical data

Dim.	mm		
	Min.	Typ.	Max.
A	4.4		4.6
B	2.5		2.7
D	2.5		2.75
E	0.45		0.7
F	0.75		1
F1	1.15		1.70
F2	1.15		1.70
G	4.95		5.2
G1	2.4		2.7
H	10		10.4
L2		16	
L3	28.6		30.6
L4	9.8		10.6
L5	2.9		3.6
L6	15.9		16.4
L7	9		9.3
Dia	3		3.2

4.2 I²PAKFP (TO-281) package information

Figure 19. I²PAKFP (TO-281) package outline

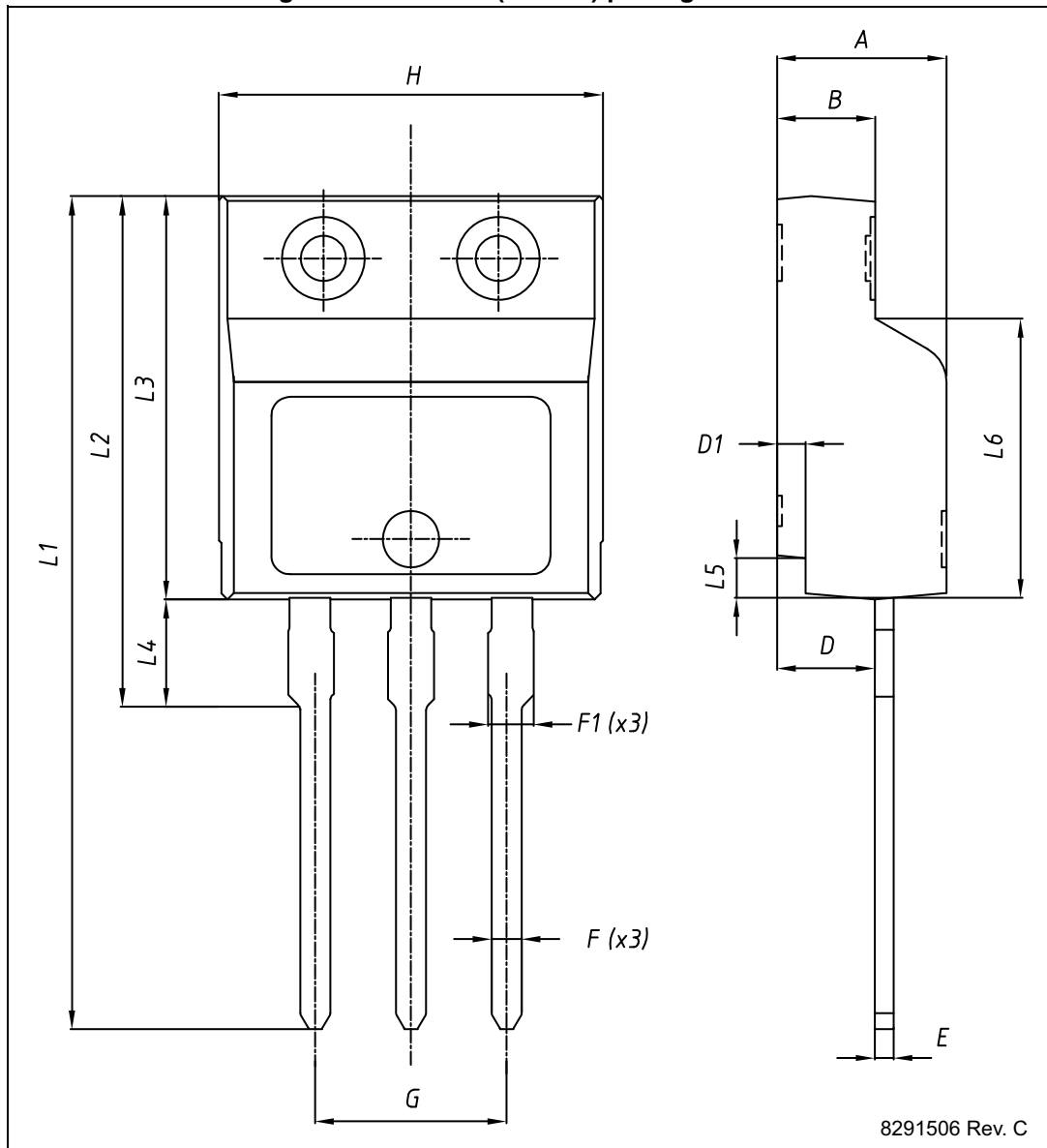

8291506 Rev. C

Table 10. I²PAKFP (TO-281) package mechanical data

Dim.	mm		
	Min.	Typ.	Max.
A	4.40		4.60
B	2.50		2.70
D	2.50		2.75
D1	0.65		0.85
E	0.45		0.70
F	0.75		1.00
F1			1.20
G	4.95		5.20
H	10.00		10.40
L1	21.00		23.00
L2	13.20		14.10
L3	10.55		10.85
L4	2.70		3.20
L5	0.85		1.25
L6	7.50	7.60	7.70

5 Revision history

Table 11. Document revision history

Date	Revision	Changes
11-May-2011	1	Initial release.
21-Jun-2011	2	Document status promoted from preliminary data to datasheet, added Section 2.1: Electrical characteristics (curves).
17-Jul-2013	3	<ul style="list-style-type: none">– Added: I²PAKFP package– Added: <i>Table 10</i> and <i>Figure 22</i>– Updated: <i>Section 4: Package information</i>– Minor text changes.
25-Jul-2016	4	The part number STF15NM65N has been moved to a separate datasheet. Minor text changes.

IMPORTANT NOTICE – PLEASE READ CAREFULLY

STMicroelectronics NV and its subsidiaries ("ST") reserve the right to make changes, corrections, enhancements, modifications, and improvements to ST products and/or to this document at any time without notice. Purchasers should obtain the latest relevant information on ST products before placing orders. ST products are sold pursuant to ST's terms and conditions of sale in place at the time of order acknowledgement.

Purchasers are solely responsible for the choice, selection, and use of ST products and ST assumes no liability for application assistance or the design of Purchasers' products.

No license, express or implied, to any intellectual property right is granted by ST herein.

Resale of ST products with provisions different from the information set forth herein shall void any warranty granted by ST for such product.

ST and the ST logo are trademarks of ST. All other product or service names are the property of their respective owners.

Information in this document supersedes and replaces information previously supplied in any prior versions of this document.

© 2016 STMicroelectronics – All rights reserved

Mouser Electronics

Authorized Distributor

Click to View Pricing, Inventory, Delivery & Lifecycle Information:

[STMicroelectronics:](#)

[STF15NM65N](#)