

General Description

The ICS9DB803D is compatible with the Intel DB800v2 Differential Buffer Specification. This buffer provides 8 PCI-Express Gen2 clocks. The ICS9DB803D is driven by a differential output pair from a CK410B+, CK505 or CK509B main clock generator.

Recommended Application

DB800v2 compatible part with PCIe Gen1 and Gen2 Support

Output Features

- 8 - 0.7V current-mode differential output pairs
- Supports zero delay buffer mode and fanout mode
- Bandwidth programming available
- 50-100 MHz operation in PLL mode
- 50-400 MHz operation in Bypass mode

Features/Benefits

- Spread spectrum modulation tolerant, 0 to -0.5% down spread and +/- 0.25% center spread
- Supports undriven differential outputs in PD# and SRC_STOP# modes for power management

Key Specifications

- Outputs cycle-cycle jitter < 50ps
- Output to Output skew <50ps
- Phase jitter: PCIe Gen1 < 86ps peak to peak
- Phase jitter: PCIe Gen2 < 3.0/3.1ps rms

Functional Block Diagram

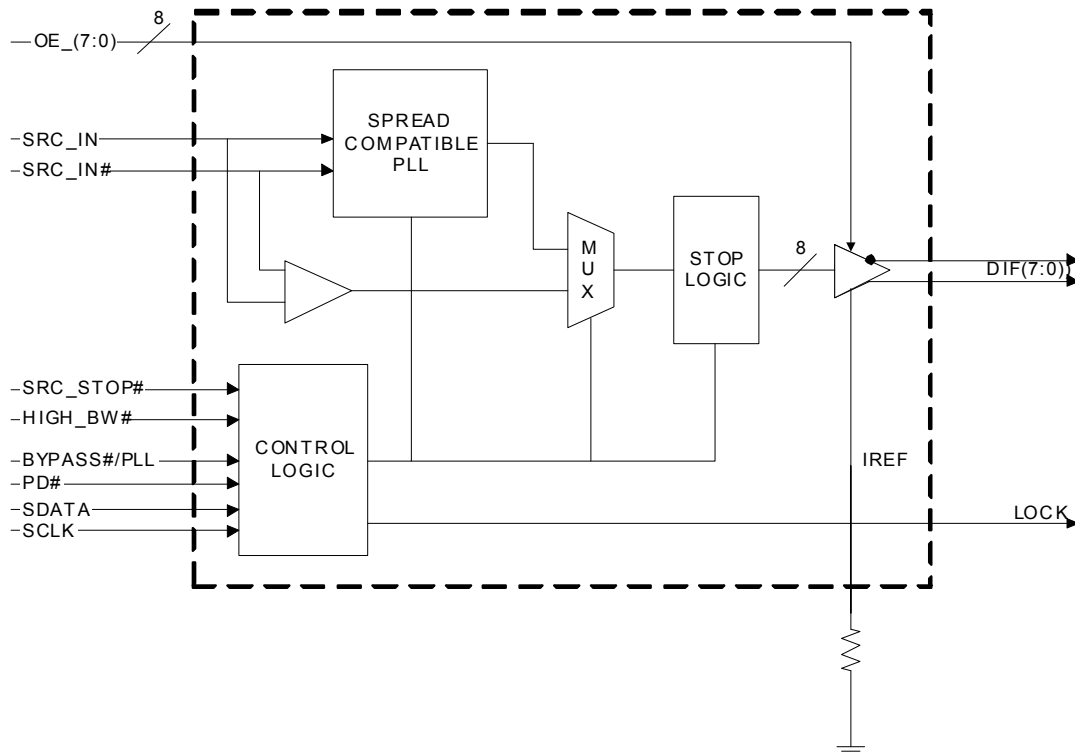

Note: Polarities shown are for OE_INV=0.

Pin Configuration

SRC_DIV#	1	48	VDDA
VDDR	2	47	GNDA
GND	3	46	IREF
SRC_IN	4	45	LOCK
SRC_IN#	5	44	OE_7
OE_0	6	43	OE_4
OE_3	7	42	DIF_7
DIF_0	8	41	DIF_7#
DIF_0#	9	40	OE_INV
GND	10	39	VDD
VDD	11	38	DIF_6
DIF_1	12	37	DIF_6#
DIF_1#	13	36	OE_6
OE_1	14	35	OE_5
OE_2	15	34	DIF_5
DIF_2	16	33	DIF_5#
DIF_2#	17	32	GND
GND	18	31	VDD
VDD	19	30	DIF_4
DIF_3	20	29	DIF_4#
DIF_3#	21	28	HIGH_BW#
BYPASS#/PLL	22	27	DIF_STOP#
SCLK	23	26	PD#
SDATA	24	25	GND

OE_INV = 0

ICS9DB803
(Same as ICS9DB108)

SRC_DIV#	1	48	VDDA
VDDR	2	47	GNDA
GND	3	46	IREF
SRC_IN	4	45	LOCK
SRC_IN#	5	44	OE7#
OE0#	6	43	OE4#
OE3#	7	42	DIF_7
DIF_0	8	41	DIF_7#
DIF_0#	9	40	OE_INV
GND	10	39	VDD
VDD	11	38	DIF_6
DIF_1	12	37	DIF_6#
DIF_1#	13	36	OE6#
OE1#	14	35	OE5#
OE2#	15	34	DIF_5
DIF_2	16	33	DIF_5#
DIF_2#	17	32	GND
GND	18	31	VDD
VDD	19	30	DIF_4
DIF_3	20	29	DIF_4#
DIF_3#	21	28	HIGH_BW#
BYPASS#/PLL	22	27	DIF_STOP
SCLK	23	26	PD
SDATA	24	25	GND

OE_INV = 1

ICS9DB803
(Same as ICS9DB801)

Power Groups

Pin Number		Description
VDD	GND	
2	3	SRC_IN/SRC_IN#
6,11,19, 31,39	10,18, 25,32	DIF(7:0)
N/A	47	IREF
48	47	Analog VDD & GND for PLL core

Polarity Inversion Pin List Table

Pins	OE_INV	
	0	1
6	OE_0	OE_0#
7	OE_3	OE_3#
14	OE_1	OE_1#
15	OE_2	OE_2#
26	PD#	PD
27	DIF_STOP#	DIF_STOP
35	OE_5	OE_5#
36	OE_6	OE_6#
43	OE_4	OE_4#
44	OE_7	OE_7#

Pin Descriptions for OE_INV=0

PIN #	PIN NAME	PIN TYPE	DESCRIPTION
1	SRC_DIV#	IN	Active low Input for determining SRC output frequency SRC or SRC/2. 0 = SRC/2, 1= SRC
2	VDDR	PWR	3.3V power for differential input clock (receiver). This VDD should be treated as an analog power rail and filtered appropriately.
3	GND	PWR	Ground pin.
4	SRC_IN	IN	0.7 V Differential SRC TRUE input
5	SRC_IN#	IN	0.7 V Differential SRC COMPLEMENTARY input
6	OE_0	IN	Active high input for enabling output 0. 0 =disable outputs, 1= enable outputs
7	OE_3	IN	Active high input for enabling output 3. 0 =disable outputs, 1= enable outputs
8	DIF_0	OUT	0.7V differential true clock output
9	DIF_0#	OUT	0.7V differential Complementary clock output
10	GND	PWR	Ground pin.
11	VDD	PWR	Power supply, nominal 3.3V
12	DIF_1	OUT	0.7V differential true clock output
13	DIF_1#	OUT	0.7V differential Complementary clock output
14	OE_1	IN	Active high input for enabling output 1. 0 =disable outputs, 1= enable outputs
15	OE_2	IN	Active high input for enabling output 2. 0 =disable outputs, 1= enable outputs
16	DIF_2	OUT	0.7V differential true clock output
17	DIF_2#	OUT	0.7V differential Complementary clock output
18	GND	PWR	Ground pin.
19	VDD	PWR	Power supply, nominal 3.3V
20	DIF_3	OUT	0.7V differential true clock output
21	DIF_3#	OUT	0.7V differential Complementary clock output
22	BYPASS#/PLL	IN	Input to select Bypass(fan-out) or PLL (ZDB) mode 0 = Bypass mode, 1= PLL mode
23	SCLK	IN	Clock pin of SMBus circuitry, 5V tolerant.
24	SDATA	I/O	Data pin for SMBus circuitry, 5V tolerant.

Pin Descriptions for OE_INV=0 (cont.)

PIN #	PIN NAME	PIN TYPE	DESCRIPTION
25	GND	PWR	Ground pin.
26	PD#	IN	Asynchronous active low input pin used to power down the device. The internal clocks are disabled and the VCO and the crystal osc. (if any) are stopped.
27	DIF_STOP#	IN	Active low input to stop differential output clocks.
28	HIGH_BW#	PWR	3.3V input for selecting PLL Band Width 0 = High, 1= Low
29	DIF_4#	OUT	0.7V differential Complementary clock output
30	DIF_4	OUT	0.7V differential true clock output
31	VDD	PWR	Power supply, nominal 3.3V
32	GND	PWR	Ground pin.
33	DIF_5#	OUT	0.7V differential Complementary clock output
34	DIF_5	OUT	0.7V differential true clock output
35	OE_5	IN	Active high input for enabling output 5. 0 =disable outputs, 1= enable outputs
36	OE_6	IN	Active high input for enabling output 6. 0 =disable outputs, 1= enable outputs
37	DIF_6#	OUT	0.7V differential Complementary clock output
38	DIF_6	OUT	0.7V differential true clock output
39	VDD	PWR	Power supply, nominal 3.3V
40	OE_INV	IN	This latched input selects the polarity of the OE pins. 0 = OE pins active high, 1 = OE pins active low (OE#)
41	DIF_7#	OUT	0.7V differential Complementary clock output
42	DIF_7	OUT	0.7V differential true clock output
43	OE_4	IN	Active high input for enabling output 4. 0 =disable outputs, 1= enable outputs
44	OE_7	IN	Active high input for enabling output 7. 0 =disable outputs, 1= enable outputs
45	LOCK	OUT	3.3V output indicating PLL Lock Status. This pin goes high when lock is achieved.
46	IREF	IN	This pin establishes the reference for the differential current-mode output pairs. It requires a fixed precision resistor to ground. 475ohm is the standard value for 100ohm differential impedance. Other impedances require different values. See data sheet.
47	GNDA	PWR	Ground pin for the PLL core.
48	VDDA	PWR	3.3V power for the PLL core.

Pin Descriptions for OE_INV=1

PIN #	PIN NAME	PIN TYPE	DESCRIPTION
1	SRC_DIV#	IN	Active low Input for determining SRC output frequency SRC or SRC/2. 0 = SRC/2, 1= SRC
2	VDDR	PWR	3.3V power for differential input clock (receiver). This VDD should be treated as an analog power rail and filtered appropriately.
3	GND	PWR	Ground pin.
4	SRC_IN	IN	0.7 V Differential SRC TRUE input
5	SRC_IN#	IN	0.7 V Differential SRC COMPLEMENTARY input
6	OE0#	IN	Active low input for enabling DIF pair 0. 1 =disable outputs, 0 = enable outputs
7	OE3#	IN	Active low input for enabling DIF pair 3. 1 =disable outputs, 0 = enable outputs
8	DIF_0	OUT	0.7V differential true clock output
9	DIF_0#	OUT	0.7V differential Complementary clock output
10	GND	PWR	Ground pin.
11	VDD	PWR	Power supply, nominal 3.3V
12	DIF_1	OUT	0.7V differential true clock output
13	DIF_1#	OUT	0.7V differential Complementary clock output
14	OE1#	IN	Active low input for enabling DIF pair 1. 1 =disable outputs, 0 = enable outputs
15	OE2#	IN	Active low input for enabling DIF pair 2. 1 =disable outputs, 0 = enable outputs
16	DIF_2	OUT	0.7V differential true clock output
17	DIF_2#	OUT	0.7V differential Complementary clock output
18	GND	PWR	Ground pin.
19	VDD	PWR	Power supply, nominal 3.3V
20	DIF_3	OUT	0.7V differential true clock output
21	DIF_3#	OUT	0.7V differential Complementary clock output
22	BYPASS#/PLL	IN	Input to select Bypass(fan-out) or PLL (ZDB) mode 0 = Bypass mode, 1= PLL mode
23	SCLK	IN	Clock pin of SMBus circuitry, 5V tolerant.
24	SDATA	I/O	Data pin for SMBus circuitry, 5V tolerant.

Pin Descriptions for OE_INV=1 (cont.)

PIN #	PIN NAME	PIN TYPE	DESCRIPTION
25	GND	PWR	Ground pin.
26	PD	IN	Asynchronous active high input pin used to power down the device. The internal clocks are disabled and the VCO is stopped.
27	DIF_STOP	IN	Active High input to stop differential output clocks.
28	HIGH_BW#	PWR	3.3V input for selecting PLL Band Width 0 = High, 1 = Low
29	DIF_4#	OUT	0.7V differential Complementary clock output
30	DIF_4	OUT	0.7V differential true clock output
31	VDD	PWR	Power supply, nominal 3.3V
32	GND	PWR	Ground pin.
33	DIF_5#	OUT	0.7V differential Complementary clock output
34	DIF_5	OUT	0.7V differential true clock output
35	OE5#	IN	Active low input for enabling DIF pair 5. 1 =disable outputs, 0 = enable outputs
36	OE6#	IN	Active low input for enabling DIF pair 6. 1 =disable outputs, 0 = enable outputs
37	DIF_6#	OUT	0.7V differential Complementary clock output
38	DIF_6	OUT	0.7V differential true clock output
39	VDD	PWR	Power supply, nominal 3.3V
40	OE_INV	IN	This latched input selects the polarity of the OE pins. 0 = OE pins active high, 1 = OE pins active low (OE#)
41	DIF_7#	OUT	0.7V differential Complementary clock output
42	DIF_7	OUT	0.7V differential true clock output
43	OE4#	IN	Active low input for enabling DIF pair 4 1 =disable outputs, 0 = enable outputs
44	OE7#	IN	Active low input for enabling DIF pair 7. 1 =disable outputs, 0 = enable outputs
45	LOCK	OUT	3.3V output indicating PLL Lock Status. This pin goes high when lock is achieved.
46	IREF	IN	This pin establishes the reference for the differential current-mode output pairs. It requires a fixed precision resistor to ground. 475ohm is the standard value for 100ohm differential impedance. Other impedances require different values. See data sheet.
47	GND A	PWR	Ground pin for the PLL core.
48	VDD A	PWR	3.3V power for the PLL core.

Absolute Maximum Ratings

Stresses above the ratings listed below can cause permanent damage to the ICS9DB803D. These ratings, which are standard values for IDT commercially rated parts, are stress ratings only. Functional operation of the device at these or any other conditions above those indicated in the operational sections of the specifications is not implied. Exposure to absolute maximum rating conditions for extended periods can affect product reliability. Electrical parameters are guaranteed only over the recommended operating temperature range.

Symbol	Parameter	Min	Max	Units
VDDA/R	3.3V Core Supply Voltage		4.6	V
VDD	3.3V Logic Supply Voltage		4.6	V
V _{IL}	Input Low Voltage	GND-0.5		V
V _{IH}	Input High Voltage		V _{DD} +0.5V	V
T _s	Storage Temperature	-65	150	°C
T _{ambient}	Commercial Operating Range	0	70	°C
	Industrial Operating Range	-40	85	°C
T _{case}	Case Temperature		115	°C
ESD _{prot}	Input ESD protection human body model	2000		V

Electrical Characteristics—Clock Input Parameters

T_A = T_{ambient} for the desired operating range, Supply Voltage V_{DD} = 3.3 V +/-5%

PARAMETER	SYMBOL	CONDITIONS	MIN	TYP	MAX	UNITS	NOTES
Input High Voltage - DIF_IN	V _{IHDIF}	Differential inputs (single-ended measurement)	600	800	1150	mV	1
Input Low Voltage - DIF_IN	V _{ILDIF}	Differential inputs (single-ended measurement)	V _{SS} - 300	0	300	mV	1
Input Common Mode Voltage - DIF_IN	V _{COM}	Common Mode Input Voltage	300		1000	mV	1
Input Amplitude - DIF_IN	V _{SWING}	Peak to Peak value (single-ended measurement)	300		1450	mV	1
Input Slew Rate - DIF_IN	dv/dt	Measured differentially	0.4		8	V/ns	1,2
Input Leakage Current	I _{IN}	V _{IN} = V _{DD} , V _{IN} = GND	-5		5	uA	1
Input Duty Cycle	d _{tin}	Measurement from differential waveform	45		55	%	1
Input Jitter - Cycle to Cycle	J _{DIFIN}	Differential Measurement	0		125	ps	1

¹ Guaranteed by design and characterization, not 100% tested in production.

² Slew rate measured through V_{swing} min centered around differential zero

Electrical Characteristics–Input/Supply/Common Output Parameters

T_A = Tambient for the desired operating range, Supply Voltage $V_{DD} = 3.3\text{ V} \pm 5\%$

PARAMETER	SYMBOL	CONDITIONS	MIN	TYP	MAX	UNITS	NOTES
Input High Voltage	V_{IHSE}	Single Ended Inputs, 3.3 V +/-5%	2		$V_{DD} + 0.3$	V	1
Input Low Voltage	V_{ILSE}		GND - 0.3		0.8	V	1
Input High Current	I_{IHSE}	$V_{IN} = V_{DD}$	-5		5	uA	1
Input Low Current	I_{IL1}	$V_{IN} = 0\text{ V}$; Inputs with no pull-up resistors	-5			uA	1
	I_{IL2}	$V_{IN} = 0\text{ V}$; Inputs with pull-up resistors	-200			uA	1
9DB803 Supply Current	$I_{DD3.3OPC}$	Full Active, $C_L =$ Full load; Commerical Temp Range		175	200	mA	1
	$I_{DD3.3OPI}$	Full Active, $C_L =$ Full load; Industrial Temp Range		190	225	mA	1
9DB803 Powerdown Current	$I_{DD3.3PDC}$	all diff pairs driven, C-Temp		50	60	mA	1
		all differential pairs tri-stated, C-Temp		4	6	mA	1
	$I_{DD3.3PDI}$	all diff pairs driven, I-temp		55	65	mA	1
		all differential pairs tri-stated, I-temp		6	8	mA	1
9DB403 Supply Current	$I_{DD3.3OPC}$	Full Active, $C_L =$ Full load; Commerical Temp Range		105	125	mA	1
	$I_{DD3.3OPI}$	Full Active, $C_L =$ Full load; Industrial Temp Range		115	150	mA	1
9DB403 Powerdown Current	$I_{DD3.3PDC}$	all diff pairs driven, C-Temp		25	30	mA	1
		all differential pairs tri-stated, C-Temp		2	3	mA	1
	$I_{DD3.3PDI}$	all diff pairs driven, I-Temp		30	35	mA	1
		all differential pairs tri-stated, I-Temp		3	4	mA	1
Input Frequency	F_{IPLL}	PCIe Mode (Bypass#/PLL= 1)	50		100	MHz	1
	$F_{IBYPASS}$	Bypass Mode ((Bypass#/PLL= 0)	33		400	MHz	1
Pin Inductance	L_{pin}				7	nH	1
Capacitance	C_{IN}	Logic Inputs, except SRC_IN	1.5		5	pF	1
	C_{INSRC_IN}	SRC_IN differential clock inputs	1.5		2.7	pF	1,4
	C_{OUT}	Output pin capacitance			6	pF	1
PLL Bandwidth	BW	-3dB point in High BW Mode	2	3	4	MHz	1
		-3dB point in Low BW Mode	0.7	1	1.4	MHz	1
PLL Jitter Peaking	t_{JPEAK}	Peak Pass band Gain		1.5	2	dB	1
Clk Stabilization	T_{STAB}	From V_{DD} Power-Up and after input clock stabilization or de-assertion of PD# to 1st clock			1	ms	1,2
Input SS Modulation Frequency	f_{MODIN}	Allowable Frequency (Triangular Modulation)	30		33	kHz	1
OE# Latency	$t_{LATO\#}$	DIF start after OE# assertion DIF stop after OE# deassertion	1		3	cycles	1,3
Tdrive_SRC_STOP#	t_{DRVSTP}	DIF output enable after SRC_Stop# de-assertion			10	ns	1,3
Tdrive_PD#	t_{DRVPD}	DIF output enable after PD# de-assertion			300	us	1,3
Tfall	t_F	Fall time of PD# and SRC_STOP#			5	ns	1
Trise	t_R	Rise time of PD# and SRC_STOP#			5	ns	2
SMBus Voltage	V_{MAX}	Maximum input voltage			5.5	V	1
Low-level Output Voltage	V_{OL}	@ I_{PULLUP}			0.4	V	1
Current sinking at V_{OL}	I_{PULLUP}		4			mA	1
SCLK/SDATA Clock/Data Rise Time	t_{RSMB}	(Max $V_{IL} - 0.15$) to (Min $V_{IH} + 0.15$)			1000	ns	1
SCLK/SDATA Clock/Data Fall Time	t_{FSMB}	(Min $V_{IH} + 0.15$) to (Max $V_{IL} - 0.15$)			300	ns	1
SMBus Operating Frequency	f_{MAXSMB}	Maximum SMBus operating frequency			100	kHz	1,5

¹Guaranteed by design and characterization, not 100% tested in production.

²See timing diagrams for timing requirements.

³Time from deassertion until outputs are >200 mV

⁴SRC_IN input

⁵The differential input clock must be running for the SMBus to be active

Electrical Characteristics–DIF 0.7V Current Mode Differential Pair

$T_A = T_{\text{ambient}}$; $V_{DD} = 3.3 \text{ V} \pm 5\%$; $C_L = 2\text{pF}$, $R_S = 33\Omega$, $R_P = 49.9\Omega$, $R_{REF} = 475\Omega$

PARAMETER	SYMBOL	CONDITIONS	MIN	TYP	MAX	UNITS	NOTES
Current Source Output Impedance	Z_o^1		3000			Ω	1
Voltage High	VHigh	Statistical measurement on single ended signal using oscilloscope math function.	660		850	mV	1,2
Voltage Low	VLow		-150		150		1,2
Max Voltage	Vovs	Measurement on single ended signal using absolute value.			1150	mV	1
Min Voltage	Vuds		-300				1
Crossing Voltage (abs)	Vcross(abs)		250		550	mV	1
Crossing Voltage (var)	d-Vcross	Variation of crossing over all edges			140	mV	1
Rise Time	t_r	$V_{OL} = 0.175\text{V}$, $V_{OH} = 0.525\text{V}$	175		700	ps	1
Fall Time	t_f	$V_{OH} = 0.525\text{V}$ $V_{OL} = 0.175\text{V}$	175		700	ps	1
Rise Time Variation	d- t_r				125	ps	1
Fall Time Variation	d- t_f				125	ps	1
Duty Cycle	d_{t3}	Measurement from differential waveform	45		55	%	1
Skew, Input to Output	t_{pdBYP}	Bypass Mode, $V_T = 50\%$	2500		4500	ps	1
	t_{pdPLL}	PLL Mode $V_T = 50\%$	-250		250	ps	1
Skew, Output to Output	t_{sk3}	$V_T = 50\%$			50	ps	1
Jitter, Cycle to cycle	$t_{jyc-cyc}$	PLL mode			50	ps	1,3
		Additive Jitter in Bypass Mode			50	ps	1,3
Jitter, Phase	$t_{jphaseBYP}$	PCIe Gen1 phase jitter (Additive in Bypass Mode)		7	10	ps (pk2pk)	1,4,5
		PCIe Gen 2 Low Band phase jitter (Additive in Bypass Mode)		0	0.1	ps (rms)	1,4,5
		PCIe Gen 2 High Band phase jitter (Additive in Bypass Mode)		0.3	0.5	ps (rms)	1,4,5
	$t_{jphasePLL}$	PCIe Gen 1 phase jitter		40	86	ps (pk2pk)	1,4,5
		PCIe Gen 2 Low Band phase jitter		1.5	3	ps (rms)	1,4,5
		PCIe Gen 2 High Band phase jitter		2.7/ 2.2	3.1	ps (rms)	1,4,5,6

¹ Guaranteed by design and characterization, not 100% tested in production.

² $I_{REF} = V_{DD}/(3 \times R_R)$. For $R_R = 475\Omega$ (1%), $I_{REF} = 2.32\text{mA}$. $I_{OH} = 6 \times I_{REF}$ and $V_{OH} = 0.7\text{V}$ @ $Z_O = 50\Omega$.

³ Measured from differential waveform

⁴ See <http://www.pcisig.com> for complete specs

⁵ Device driven by 932S421C or equivalent.

⁶ First number is High Bandwidth Mode, second number is Low Bandwidth Mode

Clock Periods–Differential Outputs with Spread Spectrum Enabled

Measurement Window		1 Clock	1us	0.1s	0.1s	0.1s	1us	1 Clock		
Symbol		Lg-	-SSC	-ppm error	0ppm	+ ppm error	+SSC	Lg+		
Definition		Absolute Period	Short-term Average	Long-Term Average	Period	Long-Term Average	Short-term Average	Period		
		Minimum Absolute Period	Minimum Absolute Period	Minimum Absolute Period	Nominal	Maximum	Maximum	Maximum	Units	Notes
Signal Name	DIF 100	9.87400	9.99900	9.99900	10.00000	10.00100	10.05130	10.17630	ns	1,2,3
	DIF 133	7.41425	7.49925	7.49925	7.50000	7.50075	7.53845	7.62345	ns	1,2,4
	DIF 166	5.91440	5.99940	5.99940	6.00000	6.00060	6.03076	6.11576	ns	1,2,4
	DIF 200	4.91450	4.99950	4.99950	5.00000	5.00050	5.02563	5.11063	ns	1,2,4
	DIF 266	3.66463	3.74963	3.74963	3.75000	3.75038	3.76922	3.85422	ns	1,2,4
	DIF 333	2.91470	2.99970	2.99970	3.00000	3.00030	3.01538	3.10038	ns	1,2,4
	DIF 400	2.41475	2.49975	2.49975	2.50000	2.50025	2.51282	2.59782	ns	1,2,4

Clock Periods–Differential Outputs with Spread Spectrum Disabled

Measurement Window		1 Clock	1us	0.1s	0.1s	0.1s	1us	1 Clock		
Symbol		Lg-	-SSC	-ppm error	0ppm	+ ppm error	+SSC	Lg+		
Definition		Absolute Period	Short-term Average	Long-Term Average	Period	Long-Term Average	Short-term Average	Period		
		Minimum Absolute Period	Minimum Absolute Period	Minimum Absolute Period	Nominal	Maximum	Maximum	Maximum	Units	Notes
Signal Name	DIF 100	9.87400		9.99900	10.00000	10.00100		10.17630	ns	1,2,3
	DIF 133	7.41425		7.49925	7.50000	7.50075		7.62345	ns	1,2,4
	DIF 166	5.91440		5.99940	6.00000	6.00060		6.11576	ns	1,2,4
	DIF 200	4.91450		4.99950	5.00000	5.00050		5.11063	ns	1,2,4
	DIF 266	3.66463		3.74963	3.75000	3.75038		3.85422	ns	1,2,4
	DIF 333	2.91470		2.99970	3.00000	3.00030		3.10038	ns	1,2,4
	DIF 400	2.41475		2.49975	2.50000	2.50025		2.59782	ns	1,2,4

¹Guaranteed by design and characterization, not 100% tested in production.

²All Long Term Accuracy specifications are guaranteed with the assumption that the input clock complies with CK409/CK410/CK505 accuracy requirements. The 9DB403/803 itself does not contribute to ppm error.

³ Driven by SRC output of main clock, PLL or Bypass mode

⁴ Driven by CPU output of CK410/CK505 main clock, **Bypass mode only**

SRC Reference Clock			
Common Recommendations for Differential Routing	Dimension or Value	Unit	Figure
L1 length, route as non-coupled 50ohm trace	0.5 max	inch	1
L2 length, route as non-coupled 50ohm trace	0.2 max	inch	1
L3 length, route as non-coupled 50ohm trace	0.2 max	inch	1
Rs	33	ohm	1
Rt	49.9	ohm	1

Down Device Differential Routing			
L4 length, route as coupled microstrip 100ohm differential trace	2 min to 16 max	inch	1
L4 length, route as coupled stripline 100ohm differential trace	1.8 min to 14.4 max	inch	1

Differential Routing to PCI Express Connector			
L4 length, route as coupled microstrip 100ohm differential trace	0.25 to 14 max	inch	2
L4 length, route as coupled stripline 100ohm differential trace	0.225 min to 12.6 max	inch	2

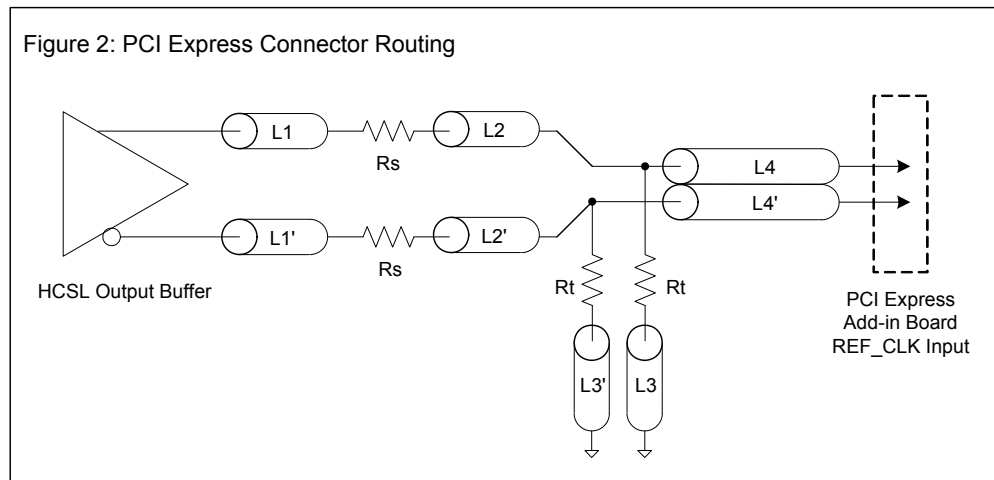
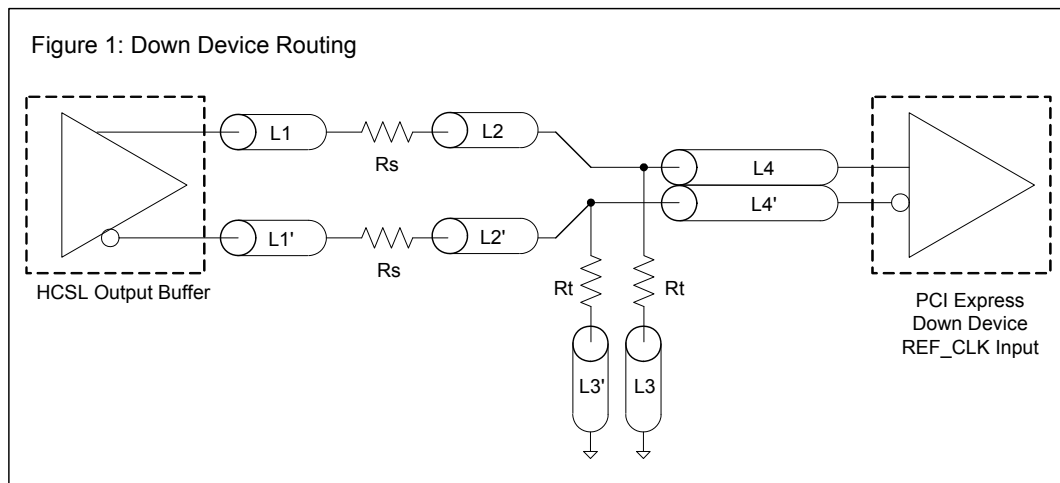

Alternative Termination for LVDS and other Common Differential Signals (figure 3)							
Vdiff	Vp-p	Vcm	R1	R2	R3	R4	Note
0.45v	0.22v	1.08	33	150	100	100	
0.58	0.28	0.6	33	78.7	137	100	
0.80	0.40	0.6	33	78.7	none	100	ICS874003i-02 input compatible
0.60	0.3	1.2	33	174	140	100	Standard LVDS

R1a = R1b = R1

R2a = R2b = R2

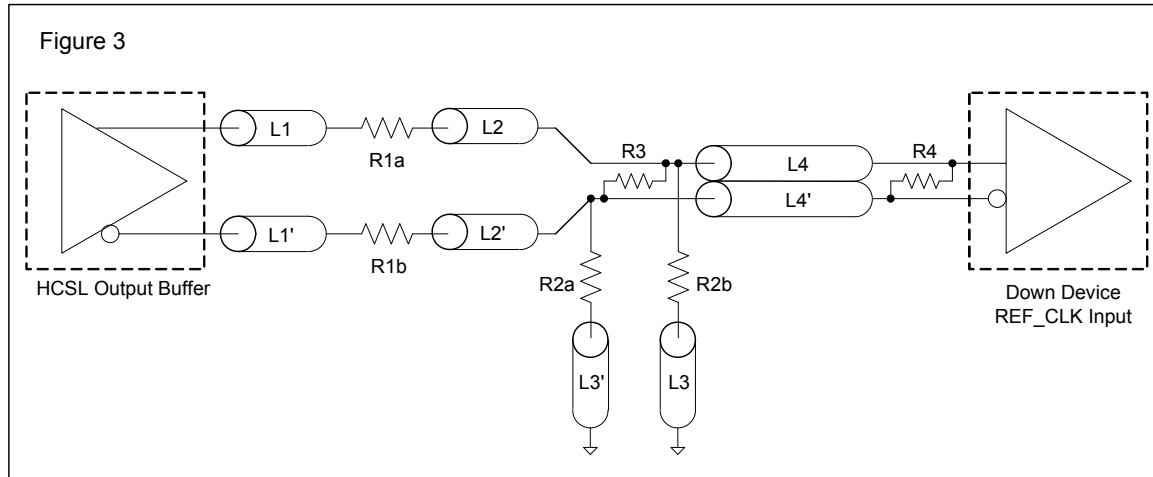

Cable Connected AC Coupled Application (figure 4)		
Component	Value	Note
R5a, R5b	8.2K 5%	
R6a, R6b	1K 5%	
Cc	0.1 μ F	
Vcm	0.350 volts	

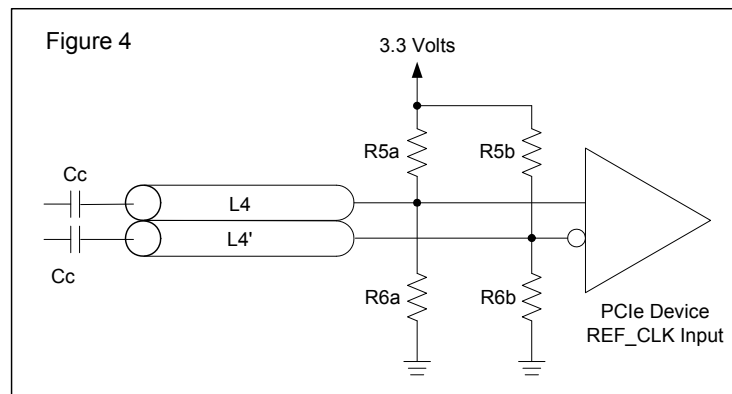

General SMBus Serial Interface Information

How to Write

- Controller (host) sends a start bit
- Controller (host) sends the write address
- IDT clock will **acknowledge**
- Controller (host) sends the beginning byte location = N
- IDT clock will **acknowledge**
- Controller (host) sends the byte count = X
- IDT clock will **acknowledge**
- Controller (host) starts sending Byte N through Byte N+X-1
- IDT clock will **acknowledge** each byte **one at a time**
- Controller (host) sends a Stop bit

Index Block Write Operation			
Controller (Host)			IDT (Slave/Receiver)
T	starT bit		
Slave Address			
WR	WRite		
Beginning Byte = N			ACK
			ACK
Data Byte Count = X			ACK
Beginning Byte N		X Byte	ACK
O			O
O			O
O			O
Byte N + X - 1			ACK
P	stoP bit		

Read Address	Write Address
DD _(H)	DC _(H)

How to Read

- Controller (host) will send a start bit
- Controller (host) sends the write address
- IDT clock will **acknowledge**
- Controller (host) sends the beginning byte location = N
- IDT clock will **acknowledge**
- Controller (host) will send a separate start bit
- Controller (host) sends the read address
- IDT clock will **acknowledge**
- IDT clock will send the data byte count = X
- IDT clock sends Byte N+X-1
- IDT clock sends **Byte 0 through Byte X (if X_(H) was written to Byte 8)**
- Controller (host) will need to acknowledge each byte
- Controller (host) will send a not acknowledge bit
- Controller (host) will send a stop bit

Index Block Read Operation			
Controller (Host)			IDT (Slave/Receiver)
T	starT bit		
Slave Address			
WR	WRite		
Beginning Byte = N			ACK
			ACK
RT	Repeat starT		
Slave Address			
RD	ReaD		
			ACK
ACK		X Byte	Data Byte Count=X
ACK			Beginning Byte N
O			O
O			O
O		O	
			Byte N + X - 1
N	Not acknowledge		
P	stoP bit		

SMBus Table: Frequency Select Register, READ/WRITE ADDRESS (DC/DD)

Byte 0	Pin #	Name	Control Function	Type	0	1	PWD
Bit 7	-	PD_Mode	PD# drive mode	RW	driven	Hi-Z	0
Bit 6	-	STOP_Mode	DIF_Stop# drive mode	RW	driven	Hi-Z	0
Bit 5	-	Reserved	Reserved	RW	Reserved		X
Bit 4	-	Reserved	Reserved	RW	Reserved		X
Bit 3	-	Reserved	Reserved	RW	Reserved		X
Bit 2	-	PLL_BW#	Select PLL BW	RW	High BW	Low BW	1
Bit 1	-	BYPASS#	BYPASS#/PLL	RW	fan-out	ZDB	1
Bit 0	-	SRC_DIV#	SRC Divide by 2 Select	RW	x/2	1x	1

SMBus Table: Output Control Register

Byte 1	Pin #	Name	Control Function	Type	0	1	PWD
Bit 7		DIF_7	Output Enable	RW	Disable	Enable	1
Bit 6		DIF_6	Output Enable	RW	Disable	Enable	1
Bit 5		DIF_5	Output Enable	RW	Disable	Enable	1
Bit 4		DIF_4	Output Enable	RW	Disable	Enable	1
Bit 3		DIF_3	Output Enable	RW	Disable	Enable	1
Bit 2		DIF_2	Output Enable	RW	Disable	Enable	1
Bit 1		DIF_1	Output Enable	RW	Disable	Enable	1
Bit 0		DIF_0	Output Enable	RW	Disable	Enable	1

SMBus Table: OE Pin Control Register Control Register

Byte 2	Pin #	Name	Control Function	Type	0	1	PWD
Bit 7		DIF_7	DIF_7 Stoppable with DIFSTOP	RW	Free-run	Stoppable	0
Bit 6		DIF_6	DIF_6 Stoppable with DIFSTOP	RW	Free-run	Stoppable	0
Bit 5		DIF_5	DIF_5 Stoppable with DIFSTOP	RW	Free-run	Stoppable	0
Bit 4		DIF_4	DIF_4 Stoppable with DIFSTOP	RW	Free-run	Stoppable	0
Bit 3		DIF_3	DIF_3 Stoppable with DIFSTOP	RW	Free-run	Stoppable	0
Bit 2		DIF_2	DIF_2 Stoppable with DIFSTOP	RW	Free-run	Stoppable	0
Bit 1		DIF_1	DIF_1 Stoppable with DIFSTOP	RW	Free-run	Stoppable	0
Bit 0		DIF_0	DIF_0 Stoppable with DIFSTOP	RW	Free-run	Stoppable	0

SMBus Table: Reserved Register

Byte 3	Pin #	Name	Control Function	Type	0	1	PWD
Bit 7			Reserved	RW	Reserved		X
Bit 6			Reserved	RW	Reserved		X
Bit 5			Reserved	RW	Reserved		X
Bit 4			Reserved	RW	Reserved		X
Bit 3			Reserved	RW	Reserved		X
Bit 2			Reserved	RW	Reserved		X
Bit 1			Reserved	RW	Reserved		X
Bit 0			Reserved	RW	Reserved		X

SMBus Table: Vendor & Revision ID Register

Byte 4	Pin #	Name	Control Function	Type	0	1	PWD
Bit 7	-	RID3	REVISION ID	R	-	-	X
Bit 6	-	RID2		R	-	-	X
Bit 5	-	RID1		R	-	-	X
Bit 4	-	RID0		R	-	-	X
Bit 3	-	VID3	VENDOR ID	R	-	-	0
Bit 2	-	VID2		R	-	-	0
Bit 1	-	VID1		R	-	-	0
Bit 0	-	VID0		R	-	-	1

SMBus Table: DEVICE ID

Byte 5	Pin #	Name	Control Function	Type	0	1	PWD
Bit 7	-	Device ID 7 (MSB)		RW	Device ID is 83 Hex for 9DB803 and 43 Hex for 9DB403		0
Bit 6	-	Device ID 6		RW			X
Bit 5	-	Device ID 5		RW			X
Bit 4	-	Device ID 4		RW			0
Bit 3	-	Device ID 3		RW			0
Bit 2	-	Device ID 2		RW			0
Bit 1	-	Device ID 1		RW			1
Bit 0	-	Device ID 0		RW			1

SMBus Table: Byte Count Register

Byte 6	Pin #	Name	Control Function	Type	0	1	PWD
Bit 7	-	BC7	Writing to this register configures how many bytes will be read back.	RW	-	-	0
Bit 6	-	BC6		RW	-	-	0
Bit 5	-	BC5		RW	-	-	0
Bit 4	-	BC4		RW	-	-	0
Bit 3	-	BC3		RW	-	-	0
Bit 2	-	BC2		RW	-	-	1
Bit 1	-	BC1		RW	-	-	1
Bit 0	-	BC0		RW	-	-	1

Note: Polarities in timing diagrams are shown OE_INV = 0. They are similar to OE_INV = 1.

PD#, Power Down

The PD# pin cleanly shuts off all clocks and places the device into a power saving mode. PD# must be asserted before shutting off the input clock or power to insure an orderly shutdown. PD is asynchronous active-low input for both powering down the device and powering up the device. When PD# is asserted, all clocks will be driven high, or tri-stated (depending on the PD# drive mode and Output control bits) before the PLL is shut down.

PD# Assertion

When PD# is sampled low by two consecutive rising edges of DIF#, all DIF outputs must be held High, or tri-stated (depending on the PD# drive mode and Output control bits) on the next High-Low transition of the DIF# outputs. When the PD# drive mode bit is set to '0', all clock outputs will be held with DIF driven High with 2 x IREF and DIF# tri-stated. If the PD# drive mode bit is set to '1', both DIF and DIF# are tri-stated.

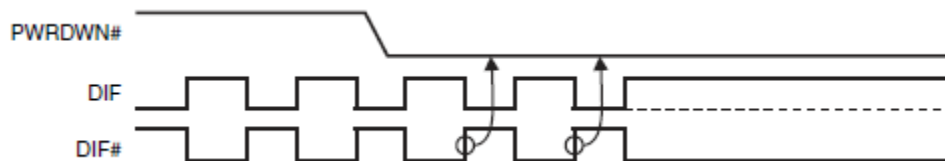

PD# De-assertion

Power-up latency is less than 1 ms. This is the time from de-assertion of the PD# pin, or VDD reaching 3.3V, or the time from valid SRC_IN clocks until the time that stable clocks are output from the device (PLL Locked). If the PD# drive mode bit is set to '1', all the DIF outputs must driven to a voltage of >200 mV within 300 us of PD# de-assertion.

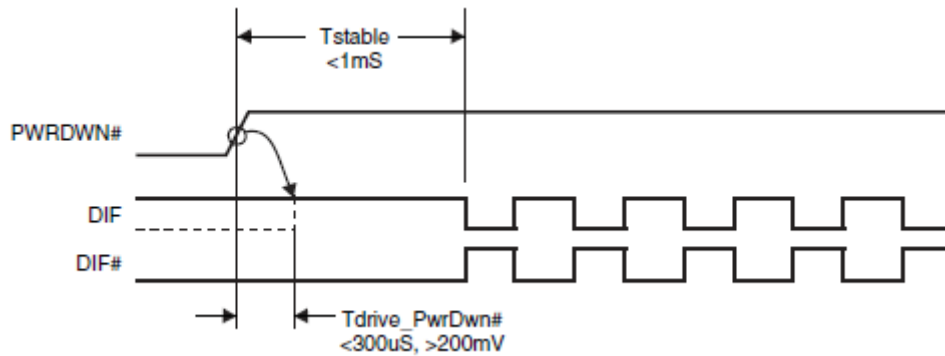

SRC_STOP#

The SRC_STOP# signal is an active-low asynchronous input that cleanly stops and starts the DIF outputs. A valid clock must be present on SRC_IN for this input to work properly. The SRC_STOP# signal is de-bounced and must remain stable for two consecutive rising edges of DIF# to be recognized as a valid assertion or de-assertion.

SRC_STOP# - Assertion

Asserting SRC_STOP# causes all DIF outputs to stop after their next transition (if the control register settings allow the output to stop). When the SRC_STOP# drive bit is '0', the final state of all stopped DIF outputs is DIF = High and DIF# = Low. There is no change in output drive current. DIF is driven with 6xIREF. DIF# is not driven, but pulled low by the termination. When the SRC_STOP# drive bit is '1', the final state of all DIF output pins is Low. Both DIF and DIF# are not driven.

SRC_STOP# - De-assertion (transition from '0' to '1')

All stopped differential outputs resume normal operation in a glitch-free manner. The de-assertion latency to active outputs is 2-6 DIF clock periods, with all DIF outputs resuming simultaneously. If the SRC_STOP# drive control bit is '1' (tri-state), all stopped DIF outputs must be driven High (>200 mV) within 10 ns of de-assertion.

SRC_STOP_1 (SRC_Stop = Driven, PD = Driven)

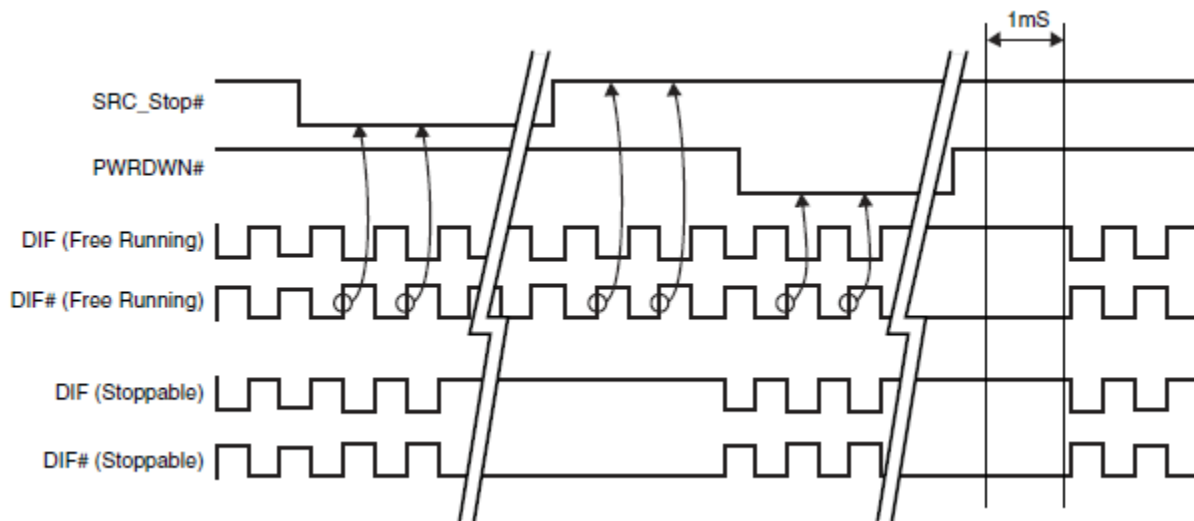

SRC_STOP_2 (SRC_Stop = Tristate, PD = Driven)

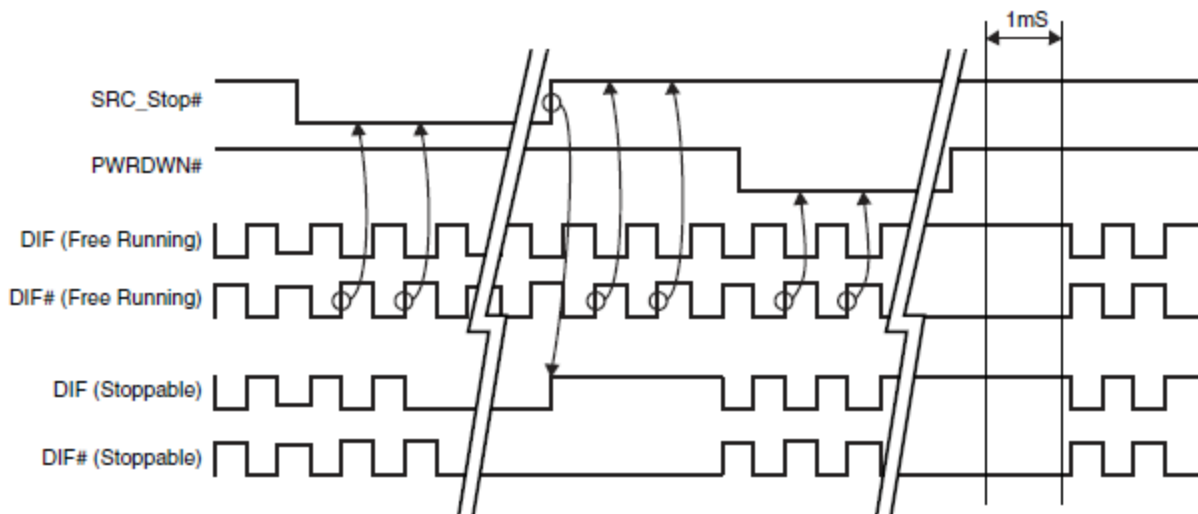

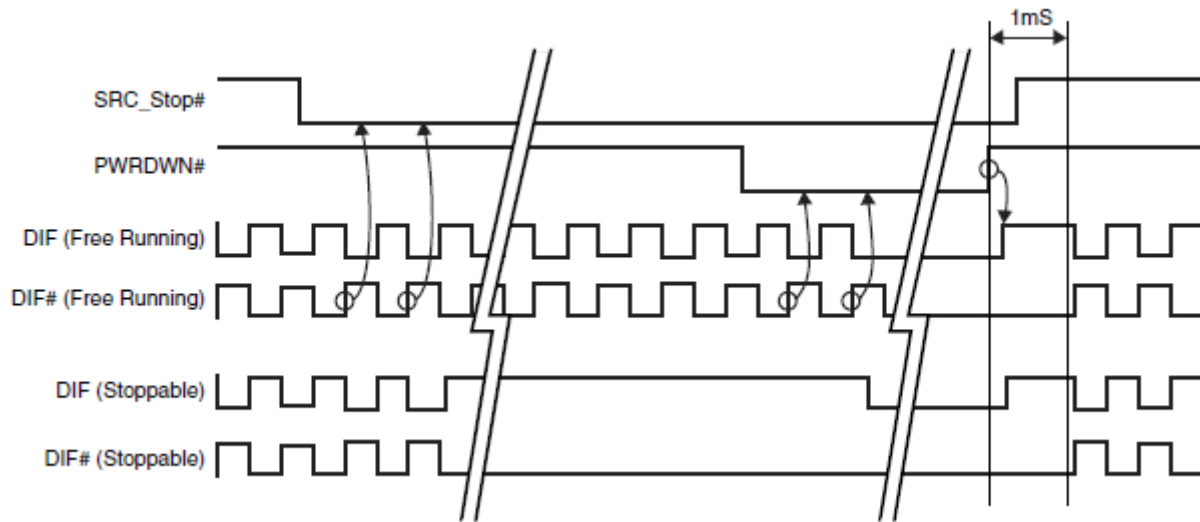
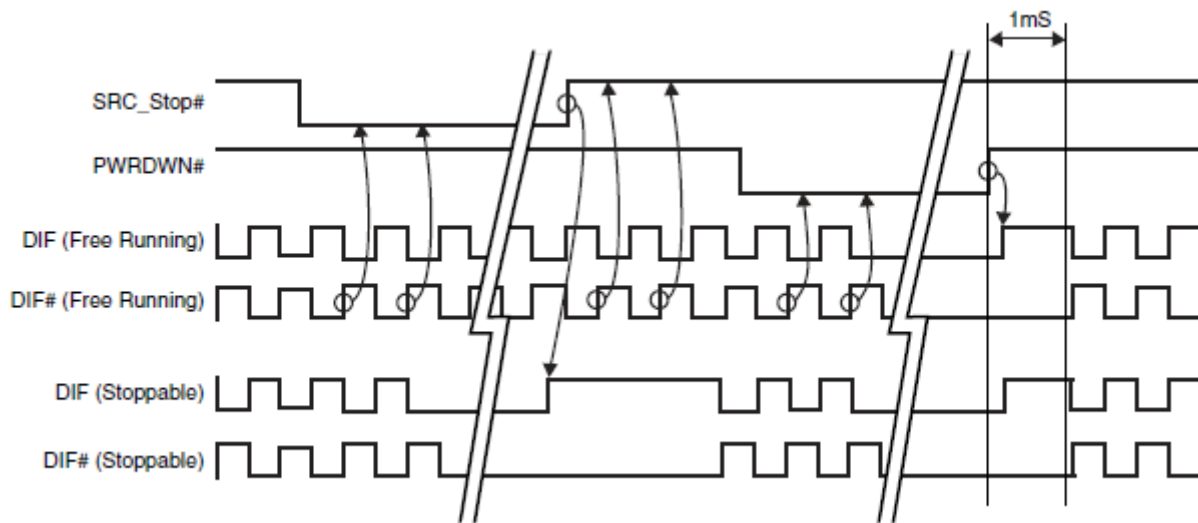
SRC_STOP_3 (SRC_Stop = Driven, PD = Tristate)**SRC_STOP_4 (SRC_Stop = Tristate, PD = Tristate)**

Package Outline and Package Dimensions (48-pin TSSOP)

Package dimensions are kept current with JEDEC Publication No. 95

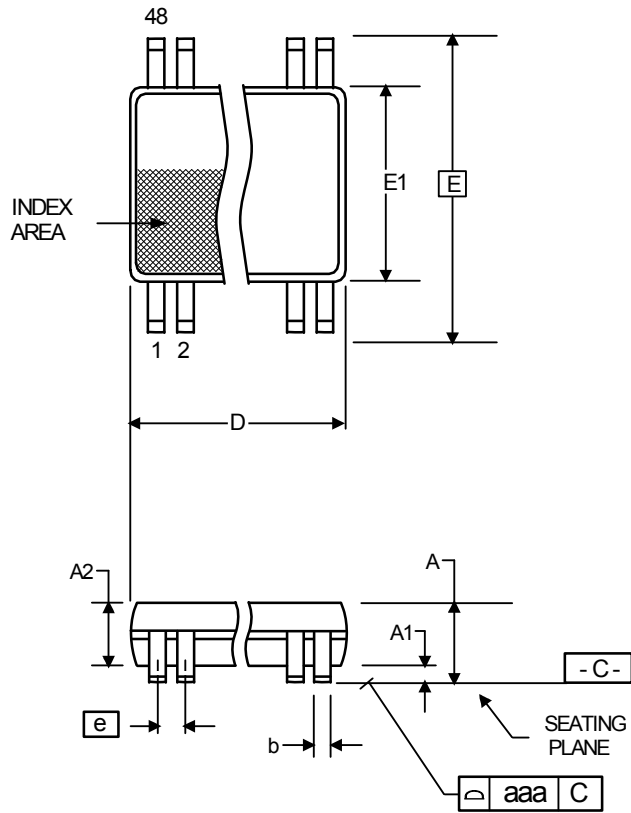

Symbol	Millimeters		Inches*	
	Min	Max	Min	Max
A	--	1.20	--	0.047
A1	0.05	0.15	0.002	0.006
A2	0.80	1.05	0.032	0.041
b	0.17	0.27	0.007	0.011
c	0.09	0.20	0.0035	0.008
D	12.40	12.60	0.488	0.496
E	8.10 BASIC		0.319 BASIC	
E1	6.00	6.20	0.236	0.244
e	0.50 Basic		0.020 Basic	
L	0.45	0.75	0.018	0.030
α	0°	8°	0°	8°
aaa	--	0.10	--	0.004

*For reference only. Controlling dimensions in mm.

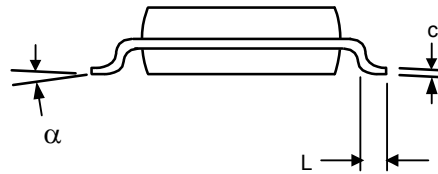

Package Outline and Package Dimensions (48-pin SSOP)

Package dimensions are kept current with JEDEC Publication No. 95

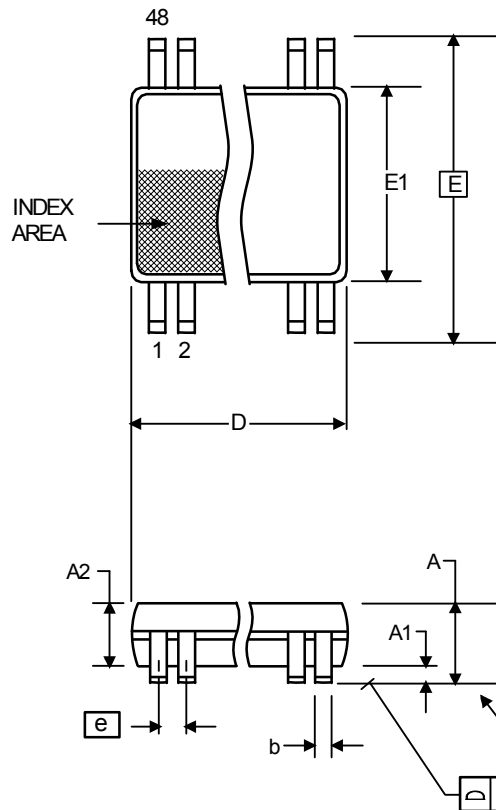

Symbol	Millimeters		Inches*	
	Min	Max	Min	Max
A	2.41	2.80	.095	.110
A1	0.20	0.40	.008	.016
b	0.20	0.34	.008	.0135
c	0.13	0.25	.005	.010
D	15.75	16.00	.620	.630
E	10.03	10.68	.395	.420
E1	7.40	7.60	.291	.299
e	0.635 BASIC		0.025 BASIC	
h	0.38	0.64	.015	.025
L	0.50	1.02	.020	.040
α	0°	8°	0°	8°

*For reference only. Controlling dimensions in mm.

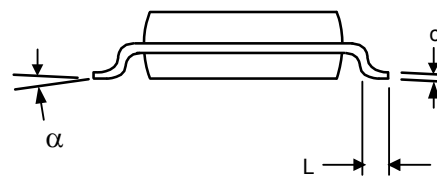

Ordering Information

Part / Order Number	Marking	Shipping Packaging	Package	Temperature
9DB803DGLF	9DB803DGLF	Tubes	48-pin TSSOP	0 to +70° C
9DB803DGLFT	9DB803DGLF	Tape and Reel	48-pin TSSOP	0 to +70° C
9DB803DGILF	9DB803DGILF	Tubes	48-pin TSSOP	-40 to +85° C
9DB803DGILFT	9DB803DGILF	Tape and Reel	48-pin TSSOP	-40 to +85° C
9DB803DFLF	9DB803DFLF	Tubes	48-pin SSOP	0 to +70° C
9DB803DFLFT	9DB803DFLF	Tape and Reel	48-pin SSOP	0 to +70° C
9DB803DFILF	9DB803DFILF	Tubes	48-pin SSOP	-40 to +85° C
9DB803DFILFT	9DB803DFILF	Tape and Reel	48-pin SSOP	-40 to +85° C

"LF" suffix to the part number are the Pb-Free configuration and are RoHS compliant.

"D" is the device revision designator (will not correlate with the datasheet revision).

While the information presented herein has been checked for both accuracy and reliability, Integrated Device Technology (IDT) assumes no responsibility for either its use or for the infringement of any patents or other rights of third parties, which would result from its use. No other circuits, patents, or licenses are implied. This product is intended for use in normal commercial applications. Any other applications such as those requiring extended temperature range, high reliability, or other extraordinary environmental requirements are not recommended without additional processing by IDT. IDT reserves the right to change any circuitry or specifications without notice. IDT does not authorize or warrant any IDT product for use in life support devices or critical medical instruments.

Revision History

Rev.	Issue Date	Issuer	Description	Page #
A	8/15/2006		Updated electrical characteristics for final data sheet	-
B			Added Input Clock Specs	
C	2/29/2008		Updated Input Clock Specs	
D	3/18/2008		Fixed typo in Input Clock Parameters	
E	3/28/2008		Updated Electrical Char tables	
F	4/10/2008		Updated Input Clock Specs	
G	1/13/2009		Corrected part ordering information	
H	10/7/2009		1. Clarified that Vih and Vil values were for Single ended inputs 2. Added Differential Clock input parameters. 3. Updated Electrical Characteristics to add propagation delay and phase noise information. 4. Added SMBus electrical characteristics 5. Added foot note about DIF input running in order for the SMBus interface to work 6. Added foot note to Byte 1 about functionality of OE bits and OE pins. 7. Updated/Reformatted General Description	Various
J	1/27/2011		Updated Termination Figure 4	12
K	5/9/2011		1. Update pin 2 pin-name and pin description from VDD to VDDR. This highlights that optimal performance is obtained by treating VDDR as in analog pin. This is a document update only, there is no silicon change.	Various
L	8/27/2012		Updated Vswing conditions to include "single-ended measurement"	7
M	9/18/2012		Updated Byte 2, bits 0~7 per char review. Outputs can be programmed with Byte 2 to be Stoppable or Free-Run with DIF_Stop pin, not the OE pins.	14
N	7/10/2013	R. Wei	Typo discovered on front page "Output Features" section. Was: "50 – 110MHz operation in PLL mode"; changed to: "50 – 100MHz operation in PLL mode"	1

IMPORTANT NOTICE AND DISCLAIMER

RENESAS ELECTRONICS CORPORATION AND ITS SUBSIDIARIES (“RENESAS”) PROVIDES TECHNICAL SPECIFICATIONS AND RELIABILITY DATA (INCLUDING DATASHEETS), DESIGN RESOURCES (INCLUDING REFERENCE DESIGNS), APPLICATION OR OTHER DESIGN ADVICE, WEB TOOLS, SAFETY INFORMATION, AND OTHER RESOURCES “AS IS” AND WITH ALL FAULTS, AND DISCLAIMS ALL WARRANTIES, EXPRESS OR IMPLIED, INCLUDING, WITHOUT LIMITATION, ANY IMPLIED WARRANTIES OF MERCHANTABILITY, FITNESS FOR A PARTICULAR PURPOSE, OR NON-INFRINGEMENT OF THIRD PARTY INTELLECTUAL PROPERTY RIGHTS.

These resources are intended for developers skilled in the art designing with Renesas products. You are solely responsible for (1) selecting the appropriate products for your application, (2) designing, validating, and testing your application, and (3) ensuring your application meets applicable standards, and any other safety, security, or other requirements. These resources are subject to change without notice. Renesas grants you permission to use these resources only for development of an application that uses Renesas products. Other reproduction or use of these resources is strictly prohibited. No license is granted to any other Renesas intellectual property or to any third party intellectual property. Renesas disclaims responsibility for, and you will fully indemnify Renesas and its representatives against, any claims, damages, costs, losses, or liabilities arising out of your use of these resources. Renesas' products are provided only subject to Renesas' Terms and Conditions of Sale or other applicable terms agreed to in writing. No use of any Renesas resources expands or otherwise alters any applicable warranties or warranty disclaimers for these products.

(Rev.1.0 Mar 2020)

Corporate Headquarters

TOYOSU FORESIA, 3-2-24 Toyosu,
Koto-ku, Tokyo 135-0061, Japan
www.renesas.com

Contact Information

For further information on a product, technology, the most up-to-date version of a document, or your nearest sales office, please visit:
www.renesas.com/contact/

Trademarks

Renesas and the Renesas logo are trademarks of Renesas Electronics Corporation. All trademarks and registered trademarks are the property of their respective owners.

Mouser Electronics

Authorized Distributor

Click to View Pricing, Inventory, Delivery & Lifecycle Information:

[Renesas Electronics:](#)

[9DB803DFLFT](#) [9DB803DGILFT](#) [9DB803DGLF](#) [9DB803DFLF](#) [9DB803DGILF](#) [9DB803DGLFT](#) [9DB803DFILFT](#)
[9DB803DFILF](#)